

Course No: EEE 6503

Course Name: Laser Theory

An Assignment on

Solid State Laser & Semiconductor Laser

Submitted to,

Dr. Md. Nasim A. Dewan

Associate Professor,

BUET.

Submitted by,

Md. Tanjib Atique Khan

Roll No.: 0412062250

Date of Submission: 27/06/2012

Bangladesh University of Engineering and Technology

Solid-State Lasers:

The oldest technology to produce laser is the optically pumped solid-state laser. The ruby laser is the first ever laser made by human. Solid-state laser consists of a crystal of glass like material doped with a small concentration of a lasing ion. Many solid-state lasers have integral harmonic generator crystals to produce visible, even UV light. Most modern solid state lasers use more efficient neodymium doped crystals such as Nd:YAG or Nd:YVO₄. There are other solid state materials of importance as well, such as erbium which is used in fiber amplifiers for communication systems, holmium and titanium which are useful in a tunable solid-state laser. In this report, two of the most important solid-state lasers are discussed. They are Ruby laser and YAG laser.

Ruby Lasers:

Ruby laser was discovered by Theodore Maiman in 1960. It is a three-level system having a high pumping threshold and requiring high pump energies. It is used as a source of intense pulsed red light for applications such as holography. The ability to Q-switch this laser results in fast, intense pulses of red light that cannot be generated by other means. Energies of 1J per pulse with a pulse length of 10 ns are common from a Q-switched ruby laser.

Lasing Medium:

As lasing medium, Ruby laser uses ruby which is synthetically grown aluminum oxide (Al₂O₃) doped with chromium ions (Cr³⁺) at a concentration of around 0.05%. It appears light pink in color, with the chromium ions giving the characteristic color of the material. As high purity is required, crystal growth is a critical matter. The ruby laser is a three-level system and so exhibits high pumping thresholds. The dynamics of ruby are poor for lasing, but its broad absorption bands and relatively long upper lasing level life time allow ruby to operate in pulsed mode, in which inversion is achieved only temporarily. The energy levels of ruby are outlined in Figure 1. The lower lasing level is the ground state itself, but this isn't one discrete level but a collection of closely spaced energy levels, normally all thermally populated. Energy is absorbed in the form of light usually from a xenon flashlamp, pumping chromium ions (Cr³⁺) to the pump levels. Pump levels have very short life times (about 1 ms), and a fast decay occurs from those

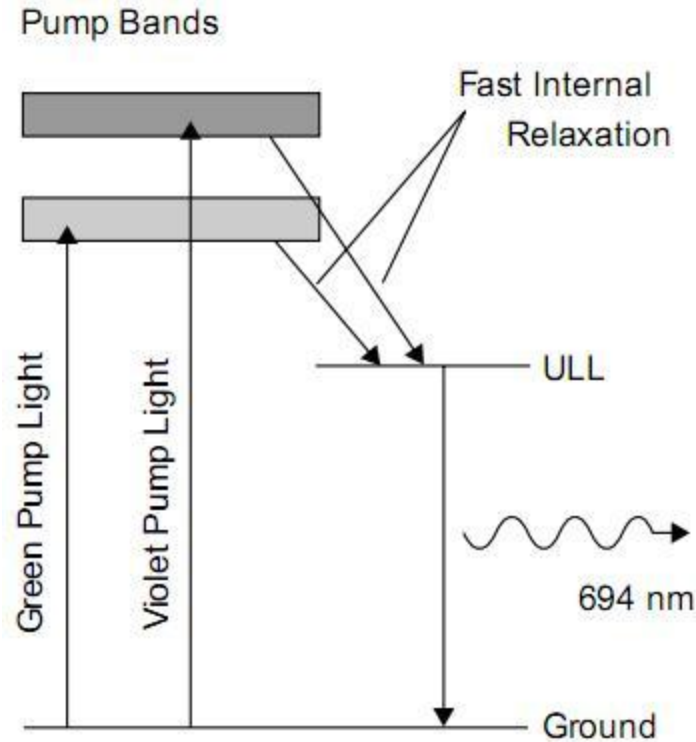

Figure 1: Energy Levels in Ruby

levels to the upper lasing level, which has a much longer life time, of 3 ms. From there, ions decay to ground state, emitting a photon of 694.3 nm light in the process. The long life time of the upper lasing level allows ruby to store energy in that level, making lasing possible as a pulse and allowing Q-switching of the laser to produce massive pulses.

Optics and Cavities:

Some compact ruby lasers use integral mirrors fabricated directly onto the ends of the rod. This is often a coating of silver or more recently, a dielectric coating. The rear of the rod is coated to reflect 100% or as close as possible, and the front of the rod is coated as an output coupler with a partial transmission. The optimal transmission is a function of the length of the rod and the pumping rate. Larger ruby lasers as well as those for special purpose applications use external optics. All solid-state laser crystals exhibit an effect called thermal lensing. When a ruby laser pumped with an intense light and cooled with flowing water, a thermal gradient will develop since the outside of the rod will be cool and the inside of the rod, relatively warm. Changes in rod temperature result in minor variances in the

indexes of refraction of the material. These changes result in a spherical lensing effect, which affects the intracavity beam exiting the rod. Localized heating may also cause thermal lensing effects. Cavity reflectors used in a ruby laser are often slightly concave to compensate for this effect.

Often, a MOPA configuration is used with two optically pumped rods in which one rod is used as an oscillator and a second as an amplifier. The oscillator is a complete laser with HR, OC, Q-switch, and intracavity optics as required. The oscillator usually produces as clean a beam as possible, which then passes through an amplifier to increase the output power by upto 10 times that of the oscillator output. Often, the amplifier has a longer rod and more pump power than the oscillator. Having a long upper lasing level life time, Q-switching is easily done with a ruby laser.

Laser Structure:

The structure of a ruby laser can vary from a simple design with integral mirrors deposited directly onto the faces of the rod, to a complex design featuring a plethora of optical elements. The optical train of a relatively complex ruby laser, a double-pulse ruby laser used for holography, is depicted in Figure 2. The cavity resonator itself consists of a dielectric high reflector and an etalon for an output coupler. Here, the etalon is a reflector, reflecting wavelengths separated by the FSR. In that respect, it simply replaces the broadband OC normally used in a laser. The single-frequency operation of this laser increases the coherence length to about 10 m, desirable when using this laser as a source for holography. Aside from frequency stability, spatial quality is also ensured through the use of a variable aperture in the optical train.

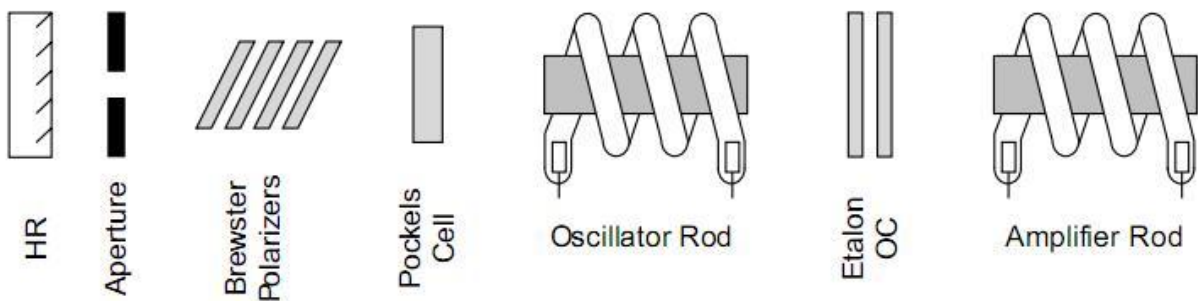

Figure 2: Optical Train of a Ruby Laser

The laser is Q-switched and uses a Pockels cell EO modulator to generate fast pulses. For this laser, two pulses are produced in rapid succession by opening the Q-switch twice. An EO switch is used since it is faster than an AO modulator and allows true modulation. It can be opened partially, allowing the first pulse to be produced without draining the entire energy of the rod. Energy left in the rod is then used to generate the second pulse. Pulses in a laser of this type must usually be balanced, so that they have the same energy. The switch is opened gradually for the first pulse, and the laser is test fired, with the energy of each pulse monitored. The process is repeated with the switch opened slightly more for the first pulse, until eventually the first pulse extracts one-half of the energy stored in the rod and the resulting two pulses are balanced.

Power Supplies:

Flashlamp pumping is the rule for supplying power to ruby lasers. Being a three-level system, pumping thresholds are quite high, with pump energies of 1000J or more common in ruby lasers. Often, the flashlamps used with ruby lasers are helical in shape, with the ruby rod at the center of the helix. Helical flashlamps have a comparatively larger volume than linear flashlamps, so can handle the higher energies required for this laser.

A flashlamp is designed to produce an intense pulse of light, usually in a short time frame ranging from micro seconds to 1 ms. The lamp itself consists of a glass tube filled with low-pressure, about 450 torr xenon gas. Electrodes at either end of the glass tube deliver current to the lamp, and triggering is accomplished either by applying an external high voltage pulse to the surface of the glass tube or superimposing a high voltage pulse across the main terminals. When the lamp fires, it exhibits a very low resistance consuming all energy from the storage capacitor, producing an intense pulse of light in the process, the spectra of the light emitted being characteristic of the gas used. In the case of ruby, xenon is used since the output is rich in blue light, which is readily absorbed by ruby.

Figure 3 shows the circuit for a typical flashlamp discharge circuit. All flashlamps, including photographic types, are quite similar in design. Capacitor C1 charges with energy from the power supply until reaching the terminal voltage, usually between 500 and 1000V. This voltage is present across the flashlamp, but the lamp

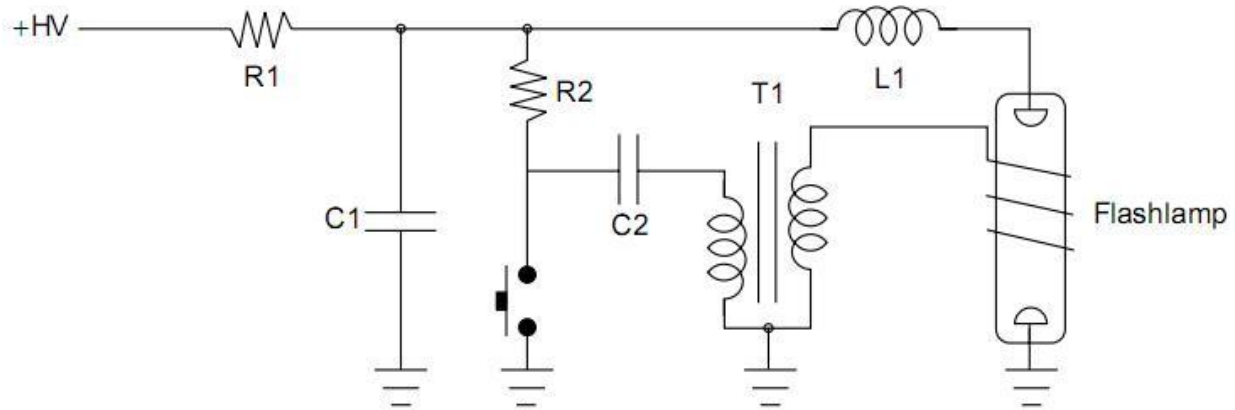

Figure 3: Flashlamp Circuit

does not ignite, since the voltage is not sufficient to cause the gas inside to ionize and conduct current. In this particular circuit a trigger pulse of between 4 and 10 kV is applied externally to the glass envelope to ionize gas in the tube and initiate the discharge. To generate the high voltage trigger pulse capacitor C2, a relatively small capacitance, charges from the main power supply through R2 and through the primary of the trigger transformer T1 itself. When the push button is pressed, the left side of C2 is grounded and current flows through the primary of T1. Being a step-up transformer, a high potential appears across the secondary of T1 sufficient to ionize gas in the lamp. Once the lamp is ionized, current flows from the main storage capacitor C1, through inductor L1, which helps form the pulse into one suitable for the lamp in what is called a critically damped LC circuit, and through the lamp, producing an intense pulse of pump light. When the capacitor has dumped all energy into the lamp, the voltage across the lamp falls to a level insufficient to sustain discharge and the discharge current through the lamp ceases. The capacitor then recharges again for the next pulse.

The external triggering method shown is used with most air-cooled flashlamps, including photographic types as well as lasers, with a very limited firing rate. Larger ruby lasers often use water-cooled flashlamps, in which the lamp and rod are both bathed in deionized water for cooling.

Output Characteristics:

Ruby lasers tend to operate in high-order transverse modes which can extract the highest powers from the rod. Restricting the mode by using an intracavity aperture can yield a TEM_{00} mode with minimal divergence for optimal beam quality, but

energy extraction is not as efficient, so power output is decreased. Q-switching decreases the energy available in a single pulse, in some cases by a factor of 100, but the peak power available is increased drastically. Where a non Q-switched laser produces pulses of about 1 ms, pulses as short as 10 ns are possible when Q-switching is employed. Peak powers of 100 MW to over 1 GW are possible, especially when a separate amplifier is used.

Applications:

The primary applications for ruby lasers now-a-days are research lasers and as sources for holography. The double-pulse ruby laser is used to record deformation of a test material by using each of the two closely spaced pulses to record a holographic image.

Another application is in the military. In U.S. M-60 tank rangefinder, a compact ruby laser was used to produce a fast, narrow pulse of light which could be reflected from a distant target to determine the range by measuring the time of flight of the laser pulse to the target and back.

YAG (Neodymium) Lasers:

Although the active lasing ion is the rare-earth metal Nd^{3+} , this laser is named after the host material and often called a YAG or glass laser. Many host materials may be used for this ion. Some of them are:

Table 1: Common Nd^{3+} Hosts and Wavelengths

Common Name	Chemical Formula and Name	Wavelength (nm)
YAG	$\text{Y}_3\text{Al}_5\text{O}_{12}$ (yttrium aluminum garnet)	1064
Vanadate	YVO_4 (yttrium o-vanadate)	1064
Glass	Various phosphate and silicate glasses	1060/1054
YLF	YLF (yttrium lithium fluoride)	1053
LSB	$\text{LaSc}_3(\text{BO}_3)_4$	1062

All of these lasers operate in a similar manner, so the term YAG is used to describe a generic neodymium laser. YAG lasers feature much higher efficiencies than ruby laser does, have lower pumping thresholds and can oscillate in CW

mode. The laser can be Q-switched, making it useful for many materials processing applications.

Lasing Medium:

Here the active lasing ion is Nd^{3+} . YAG is the most common host material, especially for medium-to high-power units, with vanadate being the favored material for low-power like $>1\text{W}$ applications. Nd:YAG is a four-level system featuring distinct upper and lower lasing levels. Multiple pump levels allow the material to absorb pump light at a variety of wavelengths in the red and near-infrared region of the spectrum. The wavelength of the resulting laser beam depends on the host material itself, which modifies the energy levels of the neodymium ion embedded in it. The absorption spectrum of YAG in Figure 4 reveals the multitude of wavelengths where pumping is possible.

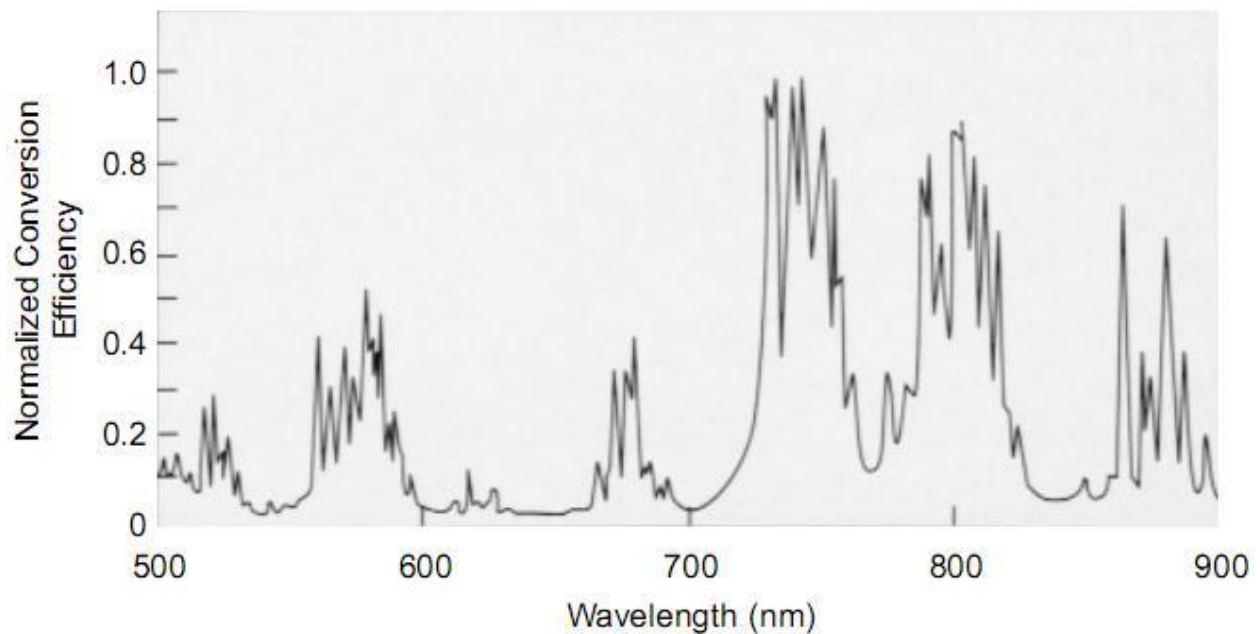

Figure 4: Absorption Spectrum of YAG

Materials other than neodymium will also lase in an almost identical configuration, including other rare-earth metals, such as holmium and erbium. Ho:YAG lases at 2060 nm and Er:YAG at 2840nm.

Optics and Cavities:

The optics for YAG lasers consists of two mirrors of which one or both are slightly spherical. Spherical mirrors are usually employed to compensate for the thermal lensing effect. The dielectric reflective coatings employed on cavity mirrors are frequently transparent to visible light allowing the use of a coaxial HeNe targeting laser to locate the infrared beam. The red HeNe beam passes through the HR, laser rod, any other components in the system, and the OC. Transparency of cavity mirrors in the visible region also helps facilitate alignment of cavity optics.

YAG lasers frequently include a Q-switch, allowing the production of fast, intense pulses. Q-switches are usually of the acousto-optic (AO) type, using inexpensive quartz or similar glass. Beam expanders are another common component found in YAG lasers. Placed between the rear optic and the rod, these components help fill the entire cross-sectional area of the rod with the intracavity beam for higher power extraction from the lasing volume. Antireflective coatings are usually deposited on the faces of rods as well as on the surfaces of optical components in the system, such as Q-switches and intracavity beam-expanding optics.

Laser Structure:

As YAG has better thermal properties, it is the popular choice for host material. YAG is not well suited for pumping with xenon lamps. Instead Krypton, with an output rich in the red region, is a better match and is used extensively for CW arc lamps used to pump YAG lasers.

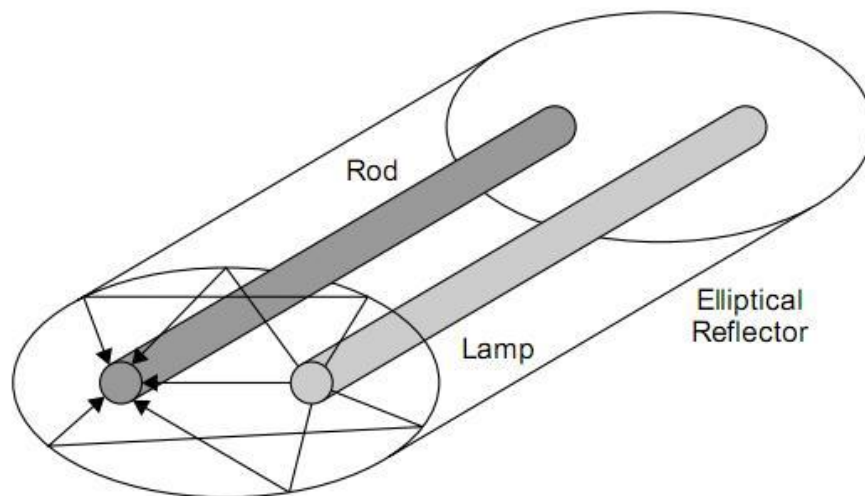

Figure 5: Elliptical reflector for lamp pumping

CW arc lamps operate at low voltages and high currents. In most YAG lasers a linear lamp is employed in which pump light from the lamp is coupled to the YAG rod via an elliptical reflector, as shown in Figure 5. By placing the YAG rod and the lamp each at a focus of the ellipse pump, light is effectively coupled to the rod. Reflectors are frequently machined from a block of stainless steel coated with pure gold since gold reflects red and IR wavelengths quite well. Gold is used here for another important reason. The reflector is usually bathed continuously in cooling water. The gold coating makes the reflector resistant to corrosion.

CW arc lamps must be water-cooled to remove the kilowatts of heat produced by

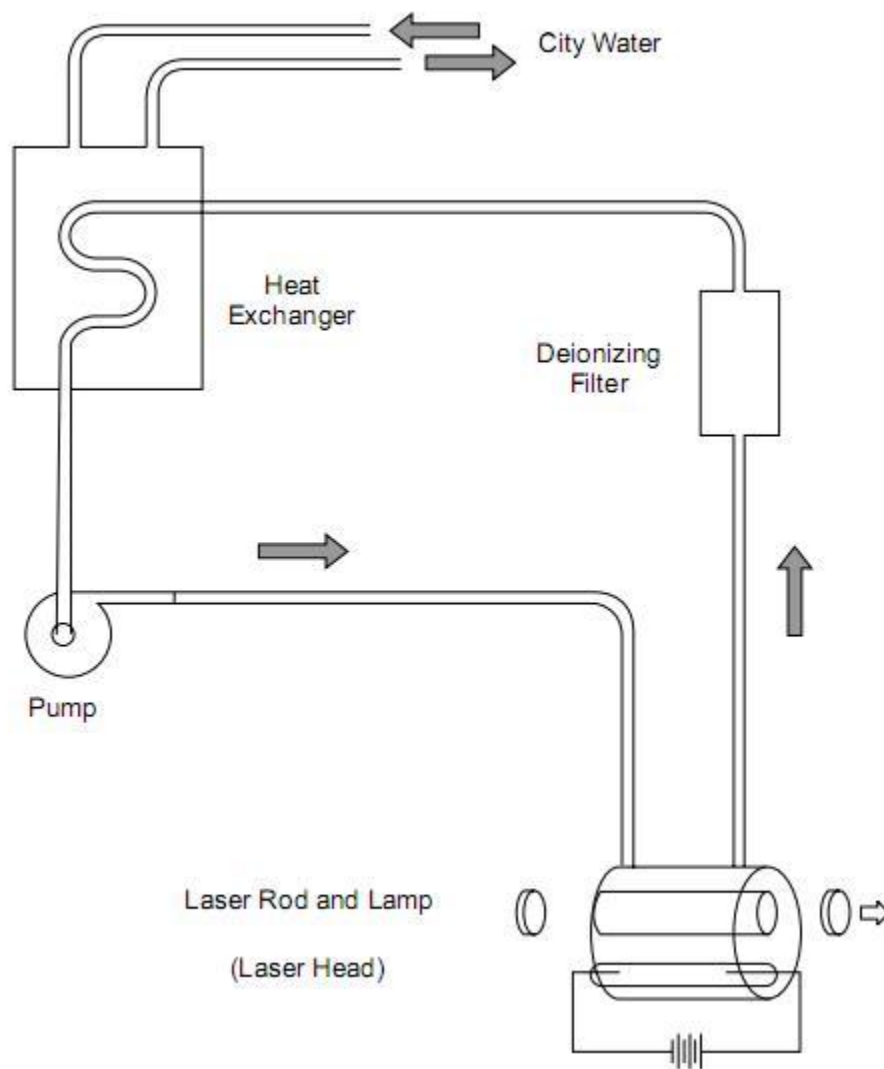

Figure 6: Water-cooling for a YAG Laser

the lamps. The entire lamp and rod are usually immersed in flowing deionized water since it is an insulator and will not short the electrical terminals of the lamp. Such lasers usually have a closed water-cooling loop in which deionized water is recirculated through the laser housing and heat is exchanged with a supply of city water. The water-cooling system for a typical YAG laser is shown in Figure 6. Large lasers are generally mounted on a rail, allowing adjustment. Use of an optical rail allows the addition of intracavity components such as Q-switches and harmonic generators as required. The highest efficiencies of YAG lasers are achieved when these materials are pumped using a semiconductor laser. Output powers are lower than possible with lamp pumping, with most diode-pumped solid-state (DPSS) lasers limited to under 5 W. Many DPSS lasers use vanadate since it has a much lower pumping threshold than YAG. Vanadate is a self-polarizing material, making design of compact SHG DPSS lasers much easier than with YAG, which is randomly polarized.

On the small end of the scale are green laser pointers. These compact units usually

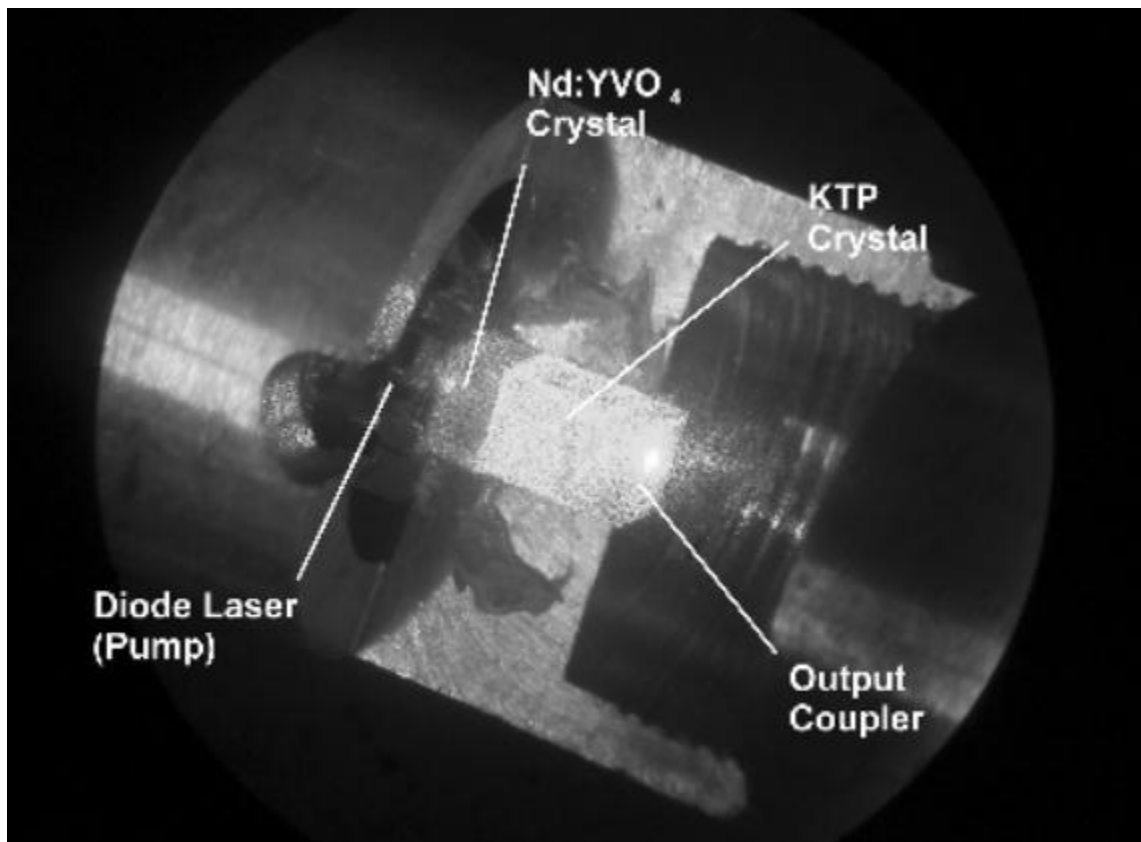

Figure 7: DPSS Laser Components

consist of a diode-pumped vanadate crystal coupled with a KTP SHG crystal. Dielectric mirrors are deposited directly onto the crystal faces, the rear coating allowing 808 nm pump light from a semiconductor laser to pass through to excite the vanadate. The entire assembly is pre-aligned as a single package, the only external component being the pump laser with associated power supply. Figure 7 details the components of a small DPSS laser used in a green laser pointer.

Upon exit from the laser, the beam passes through a collimation lens as well as a filter, which removes any 808 nm pump light or 1064 nm IR light remaining. Larger DPSS lasers tend to use separate components and optics, which also allows the inclusion of intracavity devices such as Q-switches.

Power Supplies:

Small YAG lasers use flashlamp pumping. The main difference between ruby and YAG flashlamps relates to the pump energies involved. The four-level YAG laser features a much lower pump threshold than the ruby does, so lamps tend to be smaller with 250 J. Since energies are usually lower, linear flashlamps are often used, with the pump light focused onto the rod using an elliptical reflector. Both the rod and lamp are placed at the foci of the ellipse.

Most industrial YAG lasers are pumped by a CW arc lamp. These lamps have

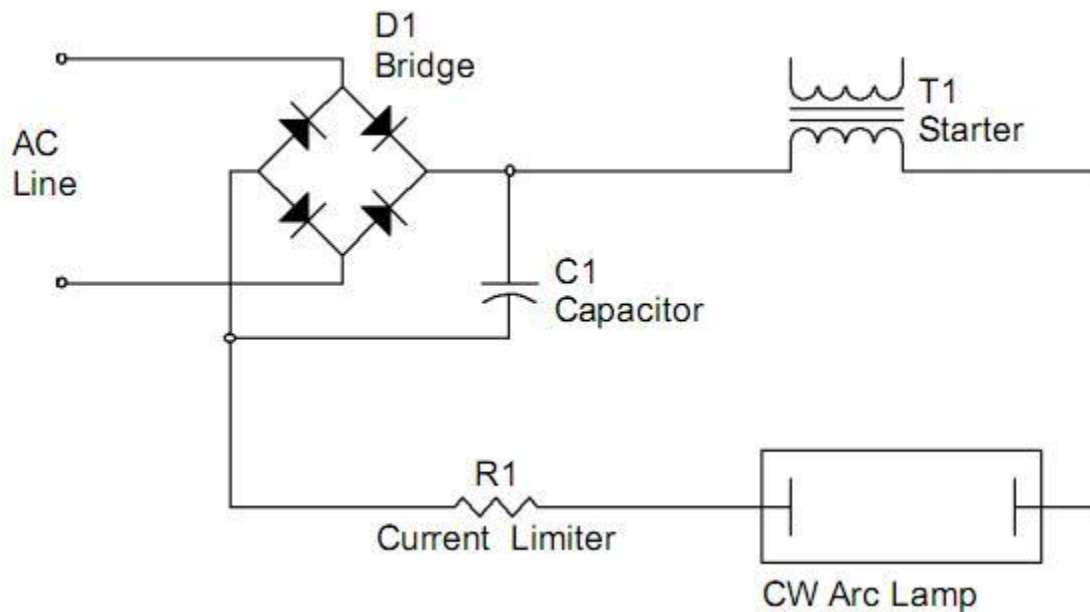

Figure 8: CW Arc Lamp Circuit

radically different power supplies from flashlamps since they require a large continuous current through the lamp. Like a flashlamp, a high-voltage trigger is required to initiate the discharge. CW arc lamps are filled with high-pressure gas usually, krypton through which an arc is sustained. Power supplies for these lamps usually involve rectification of the ac line, filtering with a capacitor, and regulation of current via a large ballast resistor or an active electronic regulator circuit, as shown in Figure 8. This particular supply uses a rather large variable resistor R1, to regulate current through the lamp. In some cases, a high-frequency AC signal is used instead of a DC capacitor discharge to ignite the lamp.

Applications, Safety and Maintenance:

YAG lasers are a workhorse for many applications involving cutting, drilling and trimming. The short pulse length possible with a Q-switched YAG laser makes it ideal for many applications where the CW carbon-di-oxide laser is not optimal. YAG lasers also work well for many marking applications. In the entertainment industry, frequency-doubled YAG lasers have been used for numerous laser light displays, especially high-power applications such as cloud writing.

Maintenance involves the usual cleaning of laser optics which is required with all other lasers. Periodic lamp changes and maintenance of the cooling-water system is also required. Filters must be changed periodically.

Although the danger involved in most lasers is quite apparent, there are a few precautions worth noting with regard to the YAG laser. This is perhaps one of the most dangerous lasers from an eye-safety stand point. As the wavelength penetrates the eye readily and Q-switched laser pulses can damage tissue rapidly, safety glasses are mandatory while working with it. The high-pressure arc lamps should be handled carefully. Because of the high pressures, the lamps have a tendency to explode during lamp changes.

Fiber Amplifiers:

A solid-state amplifier used extensively in the communications field to boost weak signals in long runs of fiber optic cables is the erbium-doped glass fiber amplifier. This amplifier consists of a long, about 10-to20-m section of glass fiber doped with

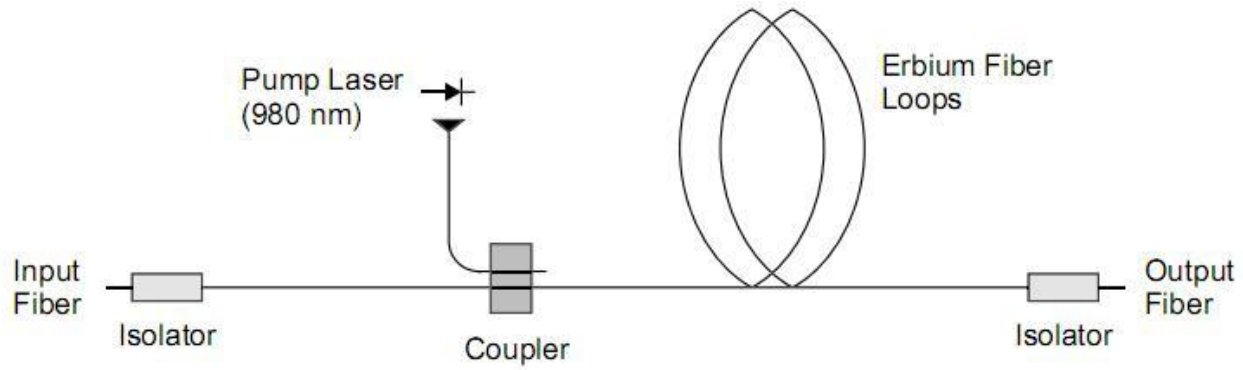

Figure 9: Erbium Fiber Amplifier

erbium ions (Er^{3+}), making an Er:glass medium. A pump laser at 980 nm is coupled to the amplifier fiber via a coupler. This pump radiation is absorbed by the erbium atoms in the fiber exciting them to an upper level which rapidly decays to a level 0.80 eV above ground state. This level, which has a relatively long spontaneous radiative lifetime can amplify incoming signals via stimulated emission, producing a net optical gain at 1549 nm. A diagram of this amplifier is shown in Figure 9. Where no input signal is present, erbium ions eventually emit spontaneous radiation which is amplified by the fiber and appears as broadband

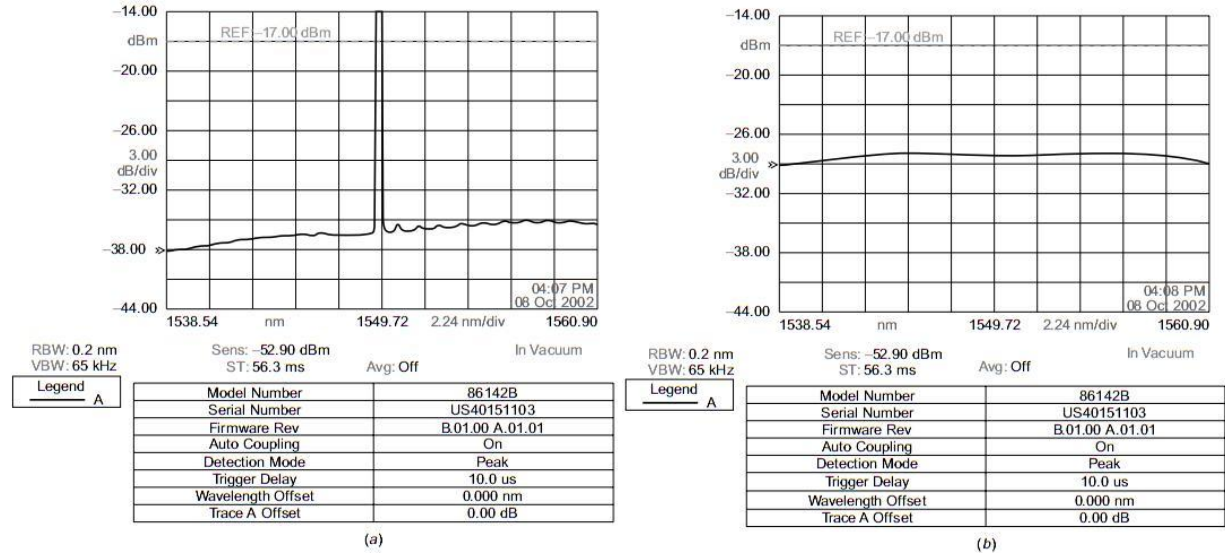

Figure 10: Fiber Amplifier Output

noise in the output called amplified spontaneous emission (ASE). Where an input signal is present, the extraordinarily long lifetime of the upper lasing level gives the ions a good chance of emitting by stimulated instead of spontaneous emission, so the amount of broadband noise in the signal is reduced drastically. The output

from such an amplifier, as analyzed on an optical spectrum analyzer is depicted in Figure 10. Although the fiber amplifier is an amplifier, not a laser—Er:glass will lase if provided with a suitable feedback mechanism.

Semiconductor Lasers:

No laser has gained such wide spread applications as the semiconductor laser. Besides being tiny, these devices are also inexpensive and require only a simple power supply to operate. Although most laser diodes operate in the infrared or red regions of the spectrum, new diodes are being developed that can produce output in the blue and violet region.

Lasing Medium:

Diode lasers work in a similar manner as the LED, with the requirement of an optical cavity for feedback and conformity to the criteria for stimulated emission and laser gain. Diode laser consists of a simple p-n junction manufactured from a material doped to have excess holes and a material doped to have excess electrons. In most laser diodes, degenerately doped semiconductor materials are used.

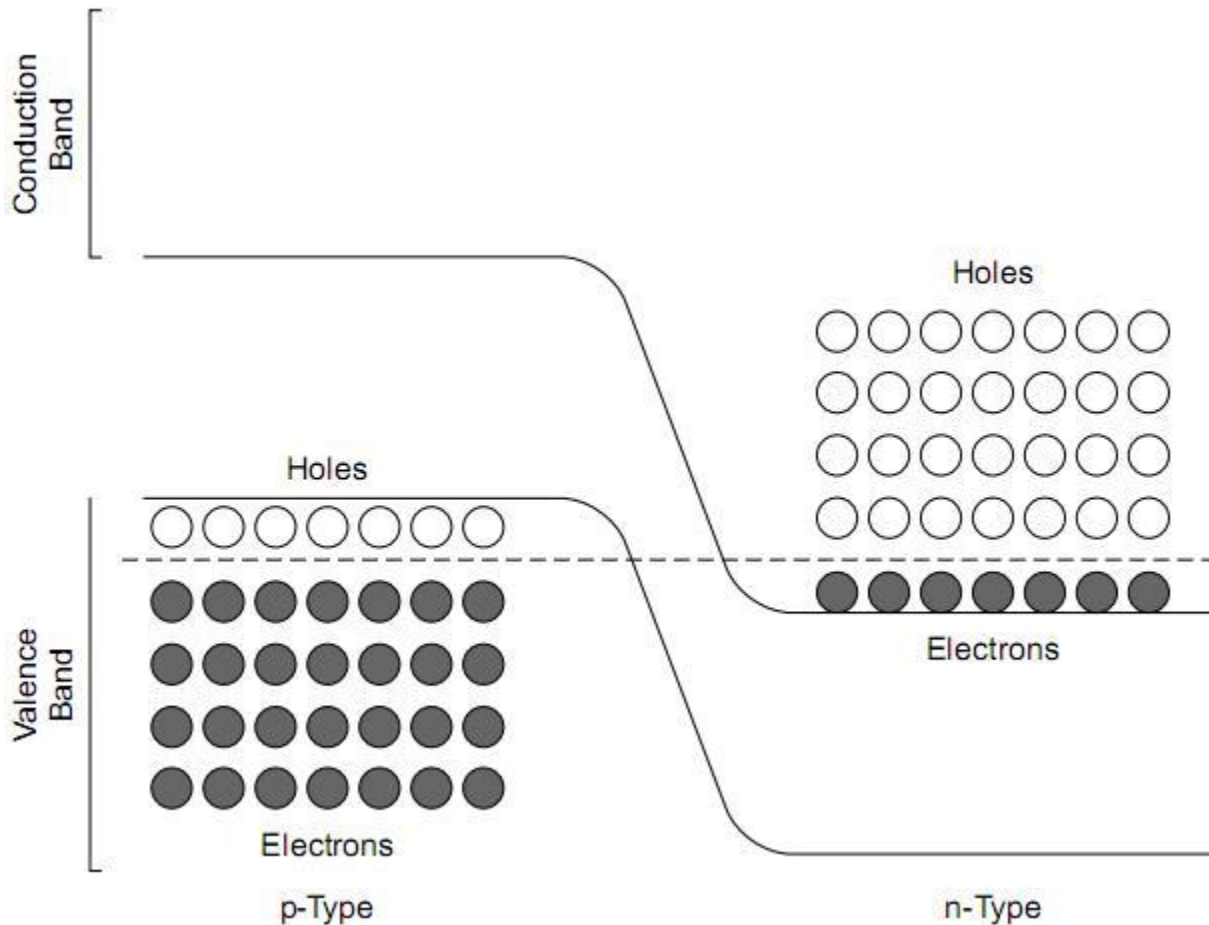

Figure 11: Energy Levels in a Degenerate Semiconductor

Degenerately doped means that the Fermi levels are actually within the valence band or the conduction band themselves, not within the bandgap. In Figure 11, the energy band diagram of a degenerate semiconductor with no external bias is shown. The dotted line is the Fermi level.

When a junction is formed with these two materials in equilibrium, a voltage develops that prevents electrons in the conduction band of the n-type material from diffusing across the barrier and combining with holes in the p-type material. Application of a voltage equal to this potential across the p-n junction causes the Fermi levels of the two materials to split into two distinct levels separated by the applied voltage. Electrons in the conduction band of the n-type material now lie just below the Fermi level of that material and holes in the valence band of the p-type material lie just above the Fermi level of that material. An inversion is generated as there are more electrons in the upper band than in the lower band.

As electrons and holes involved in the recombination process can lie anywhere in these bands, a range of wavelengths are possible, with the longest wavelengths corresponding to the bandgap energy. A sharp red cutoff is expected on the spectral output curve of such a device. Emission on the blue side of the curve also has a limiting factor brought about by the nature of the material itself.

Photons with energies corresponding to jumps within these bands encounter amplification by stimulated emission since a population inversion exists, but when the energy of an incident photon exceeds the energy corresponding to the difference between the Fermi levels, it is absorbed rapidly by electrons in the valence band of the p-type material. So, optical gain by stimulated emission can occur only for photons with a specific range of energies. Shorter wavelengths are absorbed and longer wavelengths simply lack the energy to make the transition.

Laser Structure:

The simplest structure for a laser diode is the homojunction laser diode, which uses a single junction. Light is emitted by electron–hole pair recombinations in the thin active region formed by the junction of the two materials. Usually, Gallium Arsenide (GaAs) is used, with each part of the device doped slightly differently: one part with an electron donor and one part with an electron acceptor. Mirrors for the laser cavity are fabricated simply by cleaving the crystal at right angles to the

laser axis. Having an index of refraction of 3.7, the reflectivity of each mirror may be calculated to be 33%. This represents a large loss in the cavity. Most

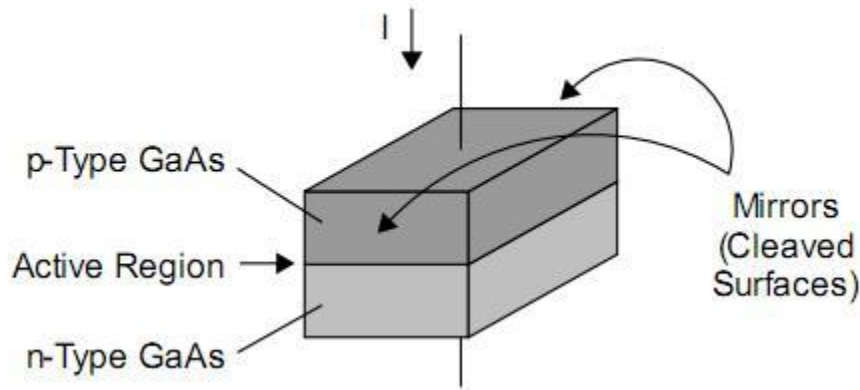

Figure 12: Homojunction Laser Structure

semiconductor laser materials have ample gain, to allow such a simple configuration. Improved performance may be achieved by fabricating a single dielectric mirror, composed of alternating quarter-wavelength-thick layers of high- and low-index-of-refraction materials, at the HR end of the laser diode. Improved mirrors are used on almost all modern laser diodes. A diagram of a simple homojunction structure is shown in Figure 12. In the figure, I is the incident current passing through the laser diode. Homojunction lasers are characterized by large threshold currents with a typical device requiring tens of Amperes to lase. Such currents prohibit continuous operation at room temperature, so CW homojunction devices require cryogenic cooling, making them impractical for many applications.

The performance of a semiconductor laser can be improved by forming two interfaces of different indexes of refraction, one on top and one below the active region confining the intracavity beam. This structure is called a heterostructure laser diode or a double heterostructure, since there are two confining interfaces. GaAs is generally used as the higher-index material and Aluminum-Gallium-Arsenide (AlGaAs) as the lower-index material. As depicted in Figure 13, AlGaAs is doped to form p- and n-type materials which essentially have identical indexes of refraction given that dopant concentration is small. Between layers of these materials, GaAs is sandwiched as the active-region material, from which laser light is emitted. Differences between the indexes of refraction occurring at each

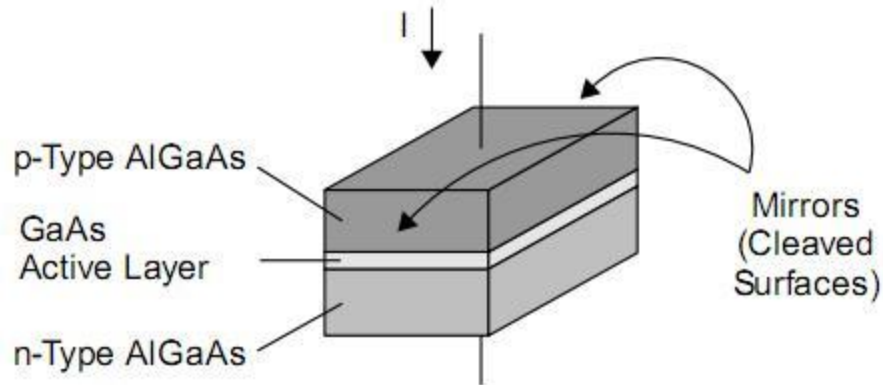

Figure 13: Heterojunction Laser Structure

interface form a reflector that confines light inside the GaAs layer, which not only improves efficiency, but also lowers threshold current for the device by increasing gain. The active region is typically only 0.1 mm in thickness. Usually, a stripe contact is used on the top of the structure to make an electrical connection to the device. This further limits the area of the active region in the GaAs laser which serves to increase current density and further lower threshold current. In a real laser diode of this type, more than three layers are generally required, and a layer that serves as an electrical interface between metal contacts and each AlGaAs layer is usually employed. Double-heterojunction laser diodes commonly operate at room temperatures with low threshold currents, in the tens-of-milliamperes range.

A further improvement in performance can be made in a buried heterostructure laser, depicted in Figure 14. In such an arrangement the entire stack of three layers

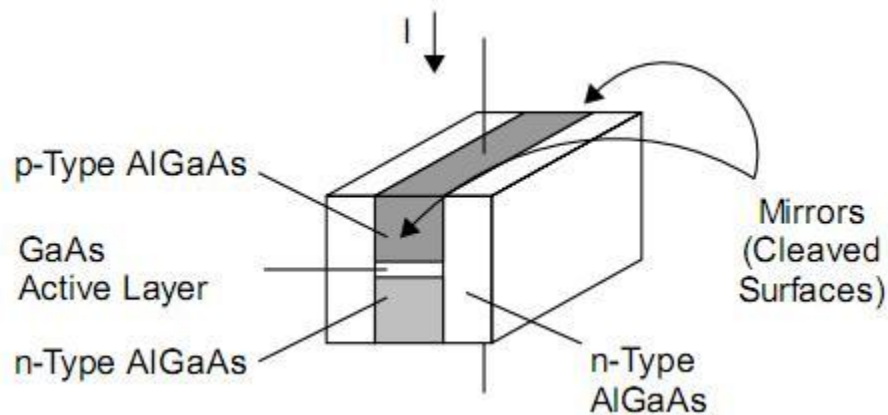

Figure 14: Buried Heterojunction Laser Structure

of a typical heterojunction laser is confined on each side by an n-type AlGaAs layer. The interface between the GaAs material in the active region, and this lower-index-of-refraction material on the sides of the active layer, serves to further confine light in the laser cavity. Such lasers are often called index-guided, since light inside the cavity is guided in a manner similar to that of an index-graded fiber optic.

One of the newest structures for semiconductor lasers is the vertical cavity surface emitting laser (VCSEL). In a laser of this type, light is not emitted from the edge of the device but rather through the entire top layer of the semiconductor crystal itself. A VCSEL produces a round beam of much higher quality. Rather than emission from the edge of the diode, light is emitted from the surface of a VCSEL. In addition to a better beam shape, VCSELs feature single longitudinal mode operation with a narrow spectral line width. Resonator optics are fabricated above and below the semiconductor crystal. With a short active layer and low gain, cavity optics must be fabricated from multiple layers of dielectrics —alternating quarter-wavelength-thick layers of high-and low-index-of-refraction materials—for high reflectivity. Current in the device flows along the optical axis through electrodes on the top and bottom of the device instead of perpendicular to it. These electrodes can be fabricated so that current flows through the mirror structure itself or through two contact layers close to the junction. The latter approach offers a lower

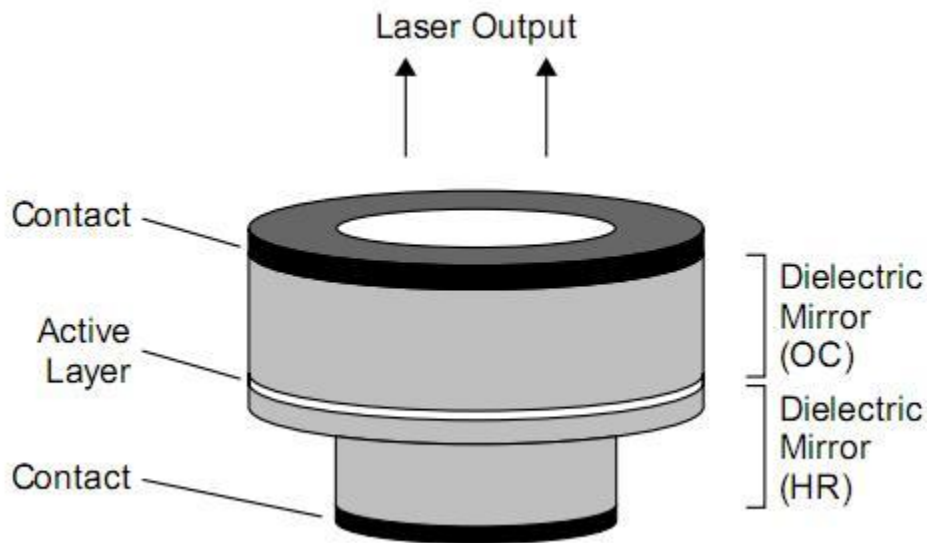

Figure 15: VCSEL Laser Structure

electrical resistance. The typical structure of a VCSEL is depicted in Figure 15. VCSEL lasers usually feature low threshold currents, often below 1 mA. Since the device does not require precision-cleaved ends to form cavity mirrors nor the deposition of multiple dielectric layers on the edges of the crystal, they may be fabricated as multiple devices on a single wafer in a manner similar to the method in which microchips are manufactured.

It is possible to optically-pump some solid-state materials. One design uses an 808 nm pump diode to optically pump a 946 nm semiconductor laser which is frequency doubled to produce 488 nm light. The arrangement is called a VECSEL (Vertical External Cavity Surface Emitting Laser), has external optics allowing inclusion of a non linear crystal inside the cavity to accomplish frequency doubling. This particular laser, which has more in common with a diode-pumped solid-state laser than a semiconductor laser, is designed as a replacement for the blue argon-ion laser.

Optics:

The simplest conventional laser diodes can use the cleaved surfaces of the semiconductor crystal as cavity reflectors. The difference of the index of refraction of the semiconductor material to the surrounding air forms a reflector with an approximately 33% reflection. Although this may seem low, semiconductor lasers typically exhibit a high-enough gain to overcome such losses. For higher efficiency, the rear surface of the semiconductor laser can be coated with a multi layer dielectric mirror to reflect almost 100% of the light emitted in that direction. The front optic on such a laser is still usually an uncoated, cleaved surface. With a short active layer, the gain is much lower in VCSELs than in edge-emitting lasers, so that dielectric mirrors fabricated from multiple layers of dielectrics, alternating quarter-wavelength-thick layers of high-and low-index-of-refraction materials, are the rule for both cavity optics for these lasers. Mirrors fabricated in such a way are highly wavelength selective, with the wavelength corresponding to the maximum gain of the semiconductor device.

The inherent spectral width of semiconductor lasers is quite large compared with a gas laser. To reduce the spectral width, wavelength selective optics may be employed in a manner similar to that used for other lasers. Given the tiny dimensions of a semiconductor laser, though, implementation of a discrete

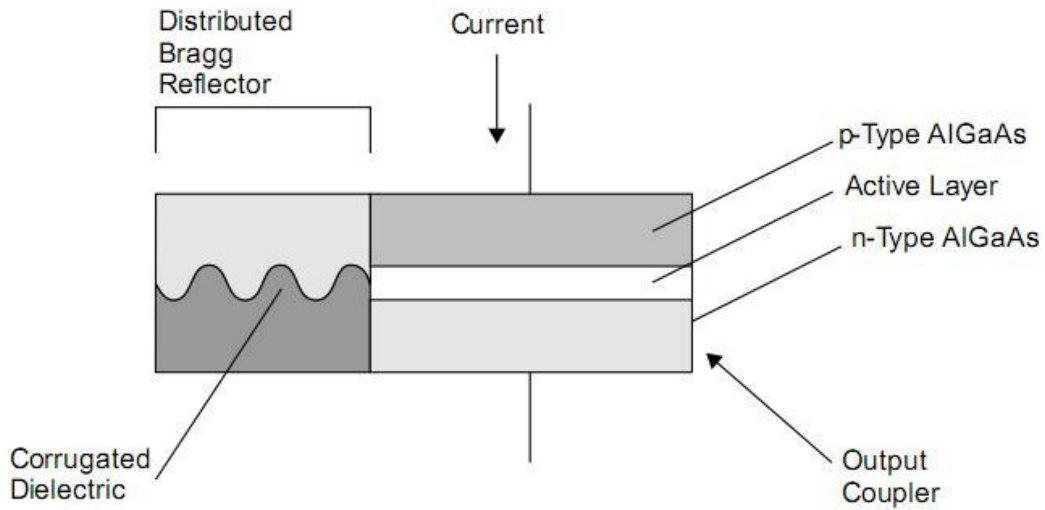

Figure 16: Distributed Bragg Reflector on a Laser Diode

diffraction grating is difficult, so the grating may be constructed as an elongated structure called a distributed Bragg reflector (DBR). Such a reflector resembles a corrugated surface manufactured from dielectric materials shown in Figure 16. Reflection of waves at the interface between two materials of different indexes of refraction leads to constructive interference at a single well-defined wavelength. Such a reflector acts much like a high-performance dielectric mirror, with the specific wavelength of maximum reflectivity called the Bragg wavelength.

Taking the DBR scheme one step further, the confining layer on one side of a regular laser diode can be replaced with a Bragg reflector fabricated in a manner

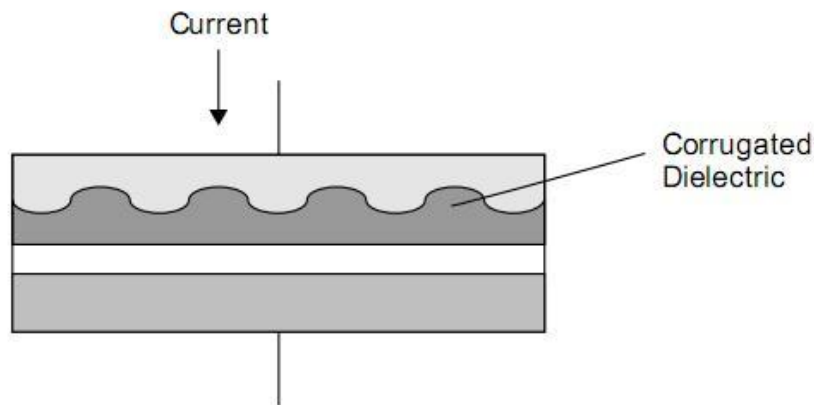

Figure 17: Distributed Feedback Laser Diode

similar to that of the DBR. In such a manner, light confined within the cavity is wavelength-selected so that only a single wavelength is amplified within the laser. This corrugated structure reflects partially at each interface between the materials of differing refractive index, so optical feedback is distributed throughout the cavity. This arrangement is called distributed feedback (DFB). The grating, again a corrugated surface composed of dielectric materials, is fabricated into the structure of the diode itself and is distributed over a considerably longer length than a traditional grating stretching over the entire length of the device. The DBR structure is shown in Figure 17. A discrete HR and OC are not required on such a device, and like the DBR laser, the wavelength of the grating determined by the spacing of the corrugations and the resulting spectral width of the output can be as low as 0.1nm.

Power Supplies:

Power supplies for laser diodes are relatively simple, providing current regulation, and often, regulation of light output. Although current regulation is sufficient, laser diode characteristics change as they heat during operation, with light output dropping as the device becomes warmer. For this reason, light feedback is often employed. Many laser diodes are fitted with a photodiode on the side of the device opposite the output, allowing the driver circuit to compensate for temperature by varying the drive current in order to maintain a constant output. Such devices are easily identified since they feature three terminals: one for the laser diode, one for the photodiode, and a third terminal common to both. A simple power supply for a laser diode is diagrammed in Figure 18.

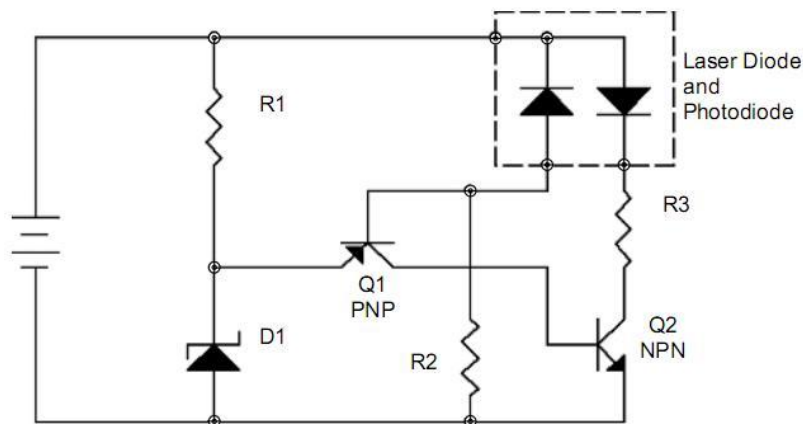

Figure 18: Laser Diode Driver

In a simplified circuit, current through the laser diode is regulated to keep constant the amount of light falling on the photodiode. As light falls onto the photodiode, current through the base of transistor Q1 decrease. In turn, current through the collector of Q1 falls, so does current through the base of Q2. Current through the collector of Q2 is hence decreased and laser diode output falls. As light output decreases from the laser, diode current through the base of Q1 increases and the reverse process occurs. The circuit reaches equilibrium and current eventually reaches a constant value.

The simplified controller shown lacks features to protect the diode from damage. Advanced diode controllers feature preset limits on laser diode current since excessive current invariably leads to destruction of the laser diode. As well, current through the laser must be damped to ensure that it does not oscillate. In addition to control of laser diode current, a temperature controller is frequently desired, which utilizes a thermoelectric cooler to keep laser diodes at a constant temperature for wavelength stability. Temperature feedback is provided, enabling the controller to sense the actual laser diode temperature and control current through the cooling module accordingly.

Output Characteristics:

The output beam from a laser diode consists of an elliptically shaped beam which is diffraction limited. Laser with narrower active layer has higher divergence at the output laser beam and vice versa. VCSELs feature a circular beam that is easier to focus to a point than is the elliptical beam. The wavelength stability of a laser diode depends highly on the temperature of the diode. As the temperature of a laser diode increases, the refractive index of the semiconductor material itself changes. Since the resonant wavelength of a cavity depends on the refractive index of the material, the wavelength shifts toward longer wavelengths as the temperature of the device increases. The output wavelength of a conventional laser diode increases more or less linearly as temperature does. Figure 19 shows the spectral output of a typical laser diode at a current of 83.9 and 111.9 mA.

Conventional laser diodes have cavity lengths which are long enough to allow several longitudinal modes to oscillate simultaneously. In the spectrum of the typical diode shown in Figure 20, modes spaced 0.288 nm apart are evident in the wavelength sweep. The resonant wavelengths of the cavity separate the output

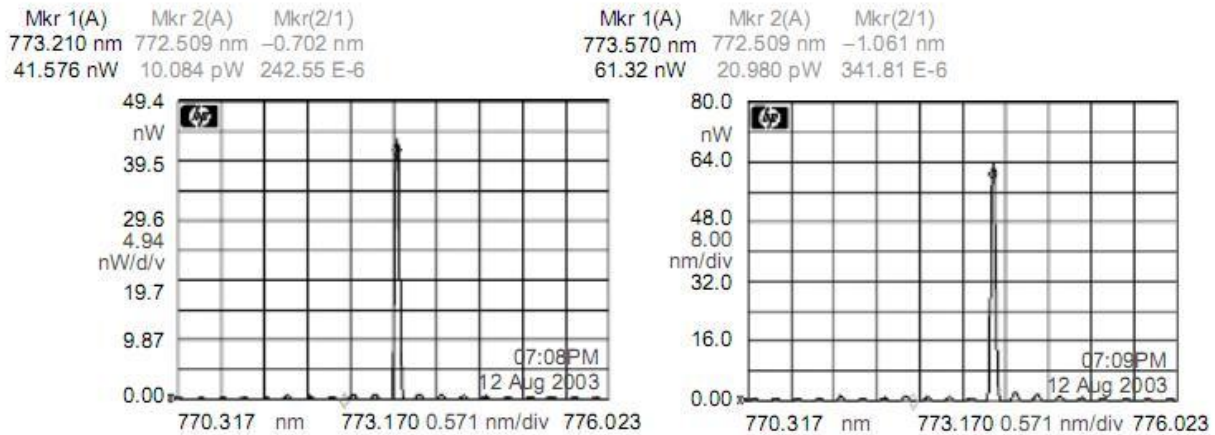

Figure 19: Laser Diode Wavelength at Increasing Current

spectrum into many modes, as evident in the figure. As the current through the device increases, a dominant mode appears and in the output. For a single-longitudinal-mode laser diode, the output wavelength can shift abruptly as the temperature fluctuates. This phenomenon is called mode hopping. This is caused by the nature of the cavity, which is resonant only at discrete wavelengths. The output of a typical diode laser is multimode, consisting of a series of peaks spaced by the FSR of the relatively small cavity, although at high drive currents a dominant mode often appears.

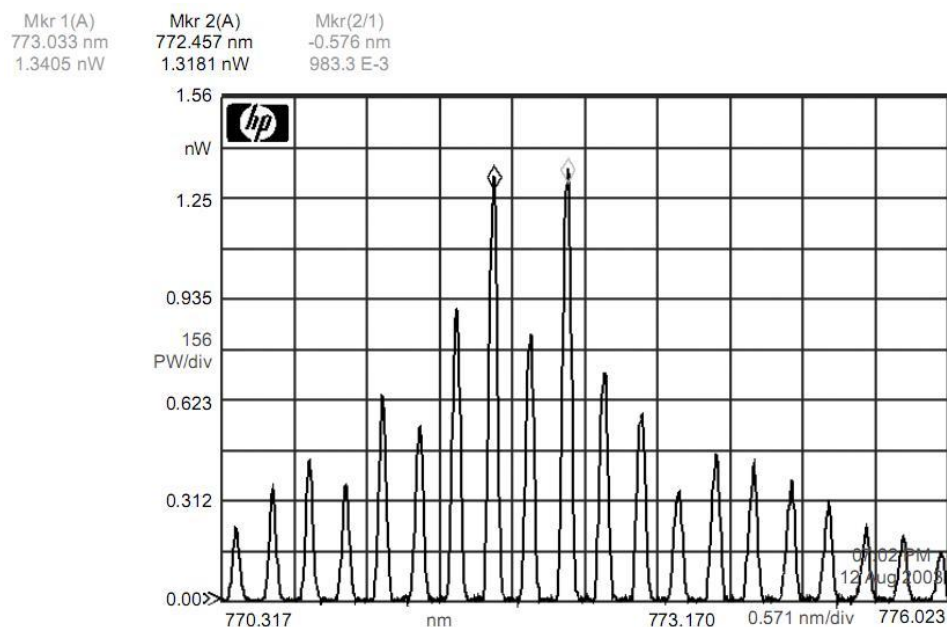

Figure 20: Laser Diode Modes

As well as longitudinal modes, transverse modes may also appear in the output, but these may be restricted in the same manner as used with other lasers, by limiting the size of the active region. Unfortunately, small apertures lead to large divergences in the output beam, so most lasers with restricted apertures require the use of an external lens to collimate the exiting beam.

Applications:

Solid-state lasers are by far the most commonly used today. Low-powered infrared lasers are employed for many optical storage applications, including CD and DVD players. Visible laser diodes are also common and used for applications ranging from laser pointers and levels to scanning applications, often replacing helium–neon lasers. For storage applications a shorter wavelength is preferred since it can be used to yield a smaller spot size and hence increase the density of optical storage media. While short-wavelength diode lasers have recently been developed, their use in optical storage devices is relatively new. There is the DPSS laser, in which a diode laser is used to pump a solid-state laser usually employing a YAG or vanadate crystal. High-powered arrays of semiconductor lasers allow the construction of DPSS lasers yielding second-harmonic powers in the tens-of-watts range, usually in the green region of the spectrum.